

**RE-ADVERTISEMENT  
REQUEST FOR PROPOSALS**

**Proposal Title:  
Duplin County Emergency Management  
Duplin County Schools  
North Duplin Elementary School Backup Generator**

**Date of Issue: January 4, 2023  
Proposals Due: February 8, 2023 2:00 pm**

**Issued for:  
North Duplin Elementary School  
157 North Duplin School Road  
Mount Olive, NC 28365**

**Issued by:  
Chelsey Lanier  
Accounting Manager  
PO Box 950  
Kenansville, NC 28349**

## KEY INFORMATION SUMMARY SHEET

**RFP Issue Date:** January 4, 2023

**Proposal Due Date:** February 8, 2023 at 2:00 PM

**Physical address to deliver proposals:** Duplin County Finance Office  
Attn: Chelsey Lanier, Accounting  
Manager 224 Seminary Street  
Kenansville, NC 28349

**Mailing address to deliver proposals:** Duplin County Finance Office  
Attn: Chelsey Lanier, Accounting  
Manager PO Box 950  
Kenansville, NC 28349

**Physical address of project:** North Duplin Elementary  
157 North Duplin School Rd  
Mount Olive, NC 28365

**Pre-Bid Conference:** A pre-bid conference will **not** be held. It will be the sole responsibility of the contractor to make suitable arrangements to visit the facility and to familiarize him/herself with the work associated with this Request for Proposal.

## **SECTION 1 PROJECT ADMINISTRATION**

### **1. Introduction**

Duplin County is seeking proposals from qualified electrical contractor companies for the installation of a backup generator to provide emergency power to the structure and grounds at North Duplin Elementary School.

Copies of the Request for Proposal (RFP) may be obtained by contacting the Duplin County Finance Office or Duplin County Emergency Management during regular business hours. The County of Duplin reserves the right to reject any and/or all proposals. The County of Duplin encourages all businesses, including disadvantaged, minority, and women owned businesses to respond to all Request for Proposals.

### **1.1 Preparation of Proposal**

Each offeror must thoroughly examine the Request for Proposal to ensure that all requirements can be met. Proposals shall be submitted on the forms included within the RFP documents. See "Proposal Submittal Format" for detailed instructions on what information to submit. Each offeror shall submit with its proposal the name, address, and telephone number of the person(s) with authority to bind the company and answer questions or provide clarification concerning the offeror's proposal.

### **1.2 Questions**

- 1.2.1 All questions pertaining to this Request for Proposal (RFP) must be submitted **in writing**, via email, no later than **5:00 PM (EST) on January 31, 2023**. Questions may be emailed to: [matthew.barwick@duplincountync.com](mailto:matthew.barwick@duplincountync.com).
- 1.2.2 Questions will be answered and posted as a memo, for public view, on [www.duplincountync.com](http://www.duplincountync.com) website. It is the responsibility of the Offeror to review the original RFP, and Addendums, and all Question/Answer Memos in their entirety.

**\*\*\*Note: To make a Site Visit Appointment, refer to Section 1.7\*\*\***

### **1.3 Submittals**

In order to be considered, all proposals must be submitted in writing on the form provided no later than **2:00 PM (EST) on February 8, 2023**. No proposal will be accepted after the official time and date. Electronic responses will not be accepted. Offerors mailing responses should allow delivery time to ensure timely receipt of their proposal. The responsibility for getting the proposal to the Duplin County Finance Office on or before the specified time and date is solely and strictly the responsibility of the responding offeror.

***The County will in no way be responsible for delays caused by any occurrence.*** Responses may be hand delivered or mailed to:

Duplin County Finance Office  
Attn: Chelsey Lanier, Accounting  
Manager 224 Seminary Street  
(hand delivery)  
PO Box 950 (mail  
delivery)  
Kenansville, NC  
28349

Hours of Operation: 8:00 a.m. - 5:00  
p.m. (EST) Monday through Friday

The outside of the envelope shall be clearly marked “**Duplin County North Duplin Elementary Backup Generator Project**”. If hand-delivering your bid, please approach the front desk receptionist, prior to the advertised closing time, requesting to enter a bid to Chelsey Lanier for this project. Should this arrival be coordinated to be at the time of bid opening, please use the same process aforementioned, further requesting to remain for the bid opening.

**1.4 Time for Acceptance**

Each proposal shall state that it is a firm offer which may be accepted within a period of 90 days from the date of the proposal.

**1.5 Cost for Proposal Preparation**

Any costs incurred by offerors in preparing or submitting offers are the offeror’s sole responsibility. The County of Duplin will not reimburse any offeror for any costs incurred prior to award.

**1.6 Offeror Responsibility**

The offeror is responsible for verifying existing conditions, measurements, square footage, and any and/all information provided and to familiarize themselves with the site location and work required, prior to submitting a proposal. Offerors are expected to examine the site prior to submitting a proposal. The County makes no guaranty or warranty, either expressed or implied, with respect to the property.

A plea of ignorance of the conditions that exist, or may hereafter exist, or difficulties that may be encountered in the execution of the work, as a result of failure to make necessary investigations and examinations, will not be accepted as an excuse for any failure, or omission on the part of the successful documents and to complete the services for the consideration set forth herein, or as a basis for any claim whatsoever.

**1.7 Site Visits**

It is highly recommended that each proposer visits the site prior to submitting a proposal. Site visits will be scheduled by appointment available through February 1, 2023, with a minimum 24 hours’ notice. Appointments will be available during normal business hours, scheduled though one of the contacts listed below.

Duplin County Schools, Special Advisor (Primary)  
Roger Jones  
rogjones@duplinschools.net  
910-290-2168

Duplin County Schools, Facility Services (Alternate)  
Jody Gurganus  
jgurganus@duplinschools.net  
910-358-4119

**1.8 References**

Offeror shall provide at least 3 references upon request.

**1.9 Evaluation**

The County of Duplin reserves the right to reject any and/or all proposals and to waive any minor

informalities in a proposal. Award will be made to the offeror who provides the lowest responsible, responsive proposal, that is most advantageous to the County.

#### **1.10 Award of Contract**

The successful offeror(s) will be notified in writing as soon as possible, after the receipt of proposals. Verbal notification of award is not considered a liable mode of notification and therefore will not be recognized as an official notification.

Upon issuance of a contract award by the County, the successful offeror(s) will provide all necessary equipment and labor necessary to perform the services as specified at the stated fees and prices, within the time specified, in accordance with all provisions of the proposal documents.

#### **1.11 Terms of Agreement**

The goods and services described in this RFP shall be paid for on a “lump sum” basis at completion and acceptance of the project.

#### **1.12 Payments**

Payment for completed services will be made upon acceptance of the services and submission of an invoice to the address initiated on the purchase order.

At a minimum, invoices will include: (1) name, address, and telephone number of the Contractor and similar information in the event payment is made to a different address, (2) the purchase order number, (3) accurate description of services rendered to include location and address, (4) total price for each element of work with sales tax shown separately, and (5) any additional payment information called for by the contract.

The County will pay the invoice within thirty (30) days or earlier after receipt of the invoice. Invoices must have the information requested above for prompt payment.

#### **1.13 Subcontract**

The successful offeror is the primary contractor and shall not subcontract the services/work without prior written approval of the County.

#### **1.14 Insurance Requirement for Service – See sample Service Agreement for limits**

The awarded vendor shall provide the County with an original Certificate of Insurance indicating that the vendor has in force the required coverage prior to the start of any work and agrees to maintain such insurance until the completion of the Contract. General liability coverage of \$1,000,000.00, Worker’s Compensation, and automobile liability insurance is required. All insurance policies shall be with insurers with an acceptable rating, registered and licensed to do business in the State of North Carolina.

Each policy shall provide a thirty (30) day notification clause in the event of cancellation, non-renewal or adverse change. In the event the insurance coverage expires prior to the completion of the project, a renewal certificate shall be on file with the Duplin County Accounting Manager at least fifteen (15) days prior to the expiration date. Failure to maintain the proper insurance will be grounds for termination of contract.

#### **1.15 Inspections and Incomplete Work**

The Contractor will be required to notify the Duplin County Building Inspections Department to obtain any and all required permits prior to commencement of the work, and to notify them when the work is completed. The Duplin County Building Inspector may perform periodic inspections of the facility and may request, at his discretion, a walk-through of the facility with the Contractor to report any discrepancies and to check the performance of the contract.

The County has the authority to point out to the Contractor incomplete or defective work and necessary corrective measures, but does not have authority to alter the terms or conditions of the contract without a written change order from the County.

### **1.16 Quality Control/Assurance**

Quality Control: The Contractor shall establish and adhere to an internal Quality Control Program to insure the quality of all work to be completed under this proposal.

Quality Assurance: The County of Duplin will monitor the Contractor's performance under this contract using the following procedures:

1. Contractor shall maintain and provide all test records, data, calculations, drawings, diagrams, manuals, specifications, and other information and documentation to industry standards, and as reasonably requested by the County.
2. All QA/QC documentation shall be compiled in a project data book issued to the County at the end of the project. The project data book shall be issued in both electronic and hardcopy formats. QA/QC documentation shall include but not be limited to: manufactured equipment specifications and O&M manuals, factory acceptance test reports, commissioning reports, and performance test data.
3. Periodic inspections by the Duplin County Building Inspections Department as may be required.
4. The Duplin County Building Inspections Department shall have the authority to stop the performance of the work for the purpose of preventing damage to the property or eliminating hazardous operations or conditions. Stoppage of work shall not constitute a basis for claim against the County.
5. The awarded engineering firm by the County will be charged with project oversight and will have the authority to stop the performance of the work for the purpose of preventing damage to the property or eliminating hazardous operations or conditions. Stoppage of work shall not constitute a basis for claim against the County.

### **1.17 Conditions to be Reported**

- 1.17.1 The Contractor shall report any circumstances of needed facility repair, to include damaged furniture and/or fixtures or unusual soiling of an area which may affect the performance of the work, any unhealthy or hazardous condition, or any delays or interference with the work caused by the employees of the County of Duplin. Such report shall be made to the Events Center Director immediately upon discovery by the Contractor.
- 1.17.2 During the period of award to acceptance, the Contractor will provide the County with project status written documentation, sent electronically, for each calendar month. This documentation will cover at a minimum: General statement of the current status of project including benchmarks met, up-to-date anticipated project completion date, and any factor that may contribute to any

extension from the previously reported anticipated project completion date.

### **1.18 Damage to Finishes and Appurtenances**

Building finishes and appurtenances damaged due to the Contractor's operations shall be repaired or replaced to a condition not less than that existing immediately prior to the damage and without cost to the County. Repairs shall be arranged by the County and paid for by the Contractor.

### **1.19 Premises and Utilities**

Duplin County Government and Duplin County Schools agree to furnish, without cost to the Contractor, limited space for storage of the Contractor's materials and equipment necessary to perform the services required under this project proposal.

Duplin County Government and Duplin County Schools will not be responsible in any way for the Contractor's supplies, materials, or equipment, or for the theft of any personal belongings of the Contractor or its employees, that is stored in the space provided by the County.

Duplin County Government and Duplin County Schools agree to furnish a reasonable amount of utilities from existing sources, to be used only in connection with the performance of the work in accordance with the terms and conditions of this contract. The Contractor is responsible for all cost of labor or materials associated with the connection and use of utilities.

The Contractor agrees to dispose of all debris generated in an appropriate manner.

The Contractor agrees to coordinate with Duplin County Schools to plan any utility outages and high-decibel emitting operations necessary to complete construction at times that do not hinder instructional times.

### **1.20 Equipment and Tools**

The Contractor shall furnish all equipment and tools necessary to properly perform the work defined in these contract documents.

All equipment used by the Contractor's employees shall meet all safety and operational requirements for performance of the work in accordance with manufacturer's specification requirements. Equipment shall be suitable for the intended purpose.

## **SECTION 2 SCOPE OF WORK**

### **2 General**

Complete all work necessary to procure, install, and test standby generator(s) to provide full-site emergency power integrated into the existing power distribution system.

- As specified by design documents, Attachment 1. Attachments specify Manual Transfer Switches. However, **ALL PROPOSALS SHOULD INCLUDE AUTOMATIC TRANSFER SWITCH IN PLACE OF THE MANUAL SWITCH SPECIFIED ON ALL APPLICATIONS.** Automatic Transfer Switches should be compatible with all applicable standards and codes and including Programmable Exercise Timer.

### **2.1 Commissioning and Startup**

Contractor shall be responsible for all initial testing, start-up, and commissioning of the new standby generator system and all associated components, with support from County personnel, including but not

limited to: conductor insulation resistance testing, visual inspection, battery checks, block heater functional checks, protective interlock functional checks and automatic transfer switch functional checks.

- Contractor shall perform load testing of generator(s) using a load bank in accordance with manufacturer recommendations.
- Contractor shall perform functional testing of the complete installed and connected standby generator system, including simulated loss and restoration of utility power utilizing actual connected loads.
- Contractor shall provide personnel and services required for testing, pre-commissioning, commissioning, start-up and site personnel training.

## 2.2 **Warranty**

Contractor shall warranty the complete standby generator system and all associated work/components for a period of 12 months following successful commissioning and acceptance testing.

# **SECTION 3 PROPOSAL REQUIREMENTS**

## 3 **Proposal Requirements**

Interested Respondents shall submit Proposals that clearly demonstrate their ability to provide the Services. The Proposal should be a complete and detailed approach to providing all Services and any Additional Services that the Respondent proposes. Only one Proposal should be submitted. Proposal must be typewritten or computer-generated. Proposals shall include the following information in the order listed below to facilitate fair and equal evaluation of Proposals.

### 3.1 **Cover Letter**

Briefly introduce the Respondent, explain the Respondent's interest in providing the Services, and articulate why the Respondent is qualified to provide the Services. Include the name, address, email address and phone number of the person who will serve as the Respondent's principle contact with County staff. Identify individual(s) who will be working on the project.

### 3.2 **Method**

Describe the Respondent's approach to the Services, including: how Respondent will work collaboratively with the County to complete deliverables; Respondent's approach to completing deliverables; and priority and scheduling. Provide information on the Respondent's current workload and ability to deliver the desired Services. If the Respondent proposes to use County-owned equipment, this must be identified.

### 3.3 **Qualifications of Contractor & Key Personnel**

Information on recent, relevant or similar services and copies of membership in any professional organizations.

3.3.1 Respondent should demonstrate relevant experience in providing services similar to the Services. Provide information about the individuals that will be assigned to the Services, including their proposed role, expertise and capabilities. Any proposed subcontractors must be identified. Full resumes can be included in an appendix.

3.3.2 The Contractor will acknowledge upon contract execution that worksite will be on educational property and under no circumstance will employees will be allowed on the jobsite who have criminal history of a felonious nature, including sexual offenders.

### 3.4 **Past Performance**

Provide two (2) client references within the past two (2) years, including contact name, firm or agency, phone number, email and brief summary of services provided. The County is especially interested in



references that can attest to the Respondent's ability and performance in similar work with similar scope of services.

### 3.5 **Exclusions & Additional Services**

The Respondent must include any proposed exclusions to the Services or draft contract, providing specific details and the reasoning behind the exclusion, and any proposed Additional Services.

### 3.6 **Additional Information**

The Respondent may list any additional information or data not requested as part of this RFP that Respondent believes should be considered in the evaluation of the Proposal.

### 3.7 **Fee Proposal**

3.7.1 Fee Proposal should be provided in a **SEPARATE SEALED ENVELOPE**.

3.7.2 A firm, fixed total price for completion of the Services. This price shall include any and all costs to perform the Services to the County's satisfaction, including but not limited to all costs for materials, labor, travel, other typical reimbursable expenses, indirect costs (i.e. overhead and general and administrative costs), profit/fee, and meetings with County staff as deemed necessary by the County throughout the duration of the Services.

3.7.3 A detailed breakdown of the total price for the Services for the entire Term. Fee proposals must include sufficient detail to allow insight into the fairness and reasonableness of the price.

3.7.4 Identify any value-added services your firm is will to provide the County at no additional cost if awarded this Project. If an additional page is attached, title the page "Value Added Services."

3.7.5 Respondents must include overview of the proposed design including quantity, size and location of generators as well as a high-level breakdown of pricing for engineering, equipment, and construction.

3.7.6 Although the County does not anticipate compensating Respondent for any additional items or expenses, any such additional amounts to be charged to the County should be identified in the fee proposal.

### 3.8 **Selection**

The County will use a qualitative-based selection process using criterion: Respondent Qualification; Past experience, representative work, and references; Proposed method and approach to fulfill the County's needs; Price.

3.8.1 Interviews may be requested once Proposals have been reviewed. The County may contact references provided with the Proposal. The County reserves the right to request clarification or additional information from Respondents and to consider independently obtained information. The County will select the Respondent determined to be the best value by the County in its sole discretion. In addition to the criteria stated above, the County's determination may consider, without limitation, the Respondent's financial resources, ability to comply with all legal and regulatory requirements, ability to perform the Services and complete the Project on time, history of performance, reputation, ability to obtain necessary equipment, data, and facilities, and any other factor deemed important by the County, including location within the County. The County may select multiple Respondents to provide Services as needed by the County.

3.8.2 The County reserves the right to negotiate further with one or more Respondent. Selection of any Contractor and execution of a contract is dependent on approval in accordance with applicable County laws and policies and the County's receipt of any required Certificates of Insurance and applicable endorsements. The County's decision is final and without recourse to any Respondent.

### 3.9 **Miscellaneous**

The issuance of this RFP and the receipt and evaluation of Proposals do not obligate the County to select a Respondent, to enter into any agreement, or to pay any costs incurred in responding to this RFP or negotiating an agreement. Selection of any Contractor and execution of a contract is dependent on

approval in accordance with applicable County laws and policies and the County's receipt of any required Certificates of Insurance and applicable endorsements. No Proposal shall constitute business terms of any eventual agreement except as expressly agreed by the County. The County reserves the right to modify this RFP or the selection process, to cancel this RFP, to reject or accept any Proposal, and to waive any informalities or irregularities in any Proposal, without liability, at any time.

- 3.9.1 All Proposals shall become the property of the County, will not be returned, and will become a public record. Respondents may request parts of their Proposals to remain confidential by indicating such in the Proposals and on the appropriate proprietary or financial pages, which must be clearly marked. The County will take reasonable steps to keep confidential only documents actually prevented from disclosure under the Freedom of Information Act, including notifying the Respondent of a FOIA request and allowing the Respondent to take steps to prevent disclosure. Under no circumstances may an entire Proposal be marked or identified as proprietary or confidential. **By submitting a Proposal, each Respondent agrees to hold the County harmless from any claims arising from the release of confidential or proprietary information not clearly designated as such by the Respondent or where the County has notified the Respondent of a request, and from any claims arising from the release of documents not protected from disclosure under the Act.**

**ATTACHMENT 1**

**NEXT PAGE**



## Duplin County Emergency Management

<https://www.duplincountync.com/fire-emergencymanagement/>

209 Seminary Street • Kenansville, NC 28349

Tel 910-296-2160 • Fax 910-296-2164

Brian Matthis, Emergency Management Planner  
Chris Vernon, 911 Communications Director

Michael J. Mahoney, Deputy Fire Marshal  
Brittany Malone, Administrative Support Specialist  
Matthew Barwick, Director/Fire Marshal

Date: December 15, 2022

RE: RFP Questions - Duplin County Emergency Management/ Duplin County Schools  
Rose Hill-Magnolia Elementary School Backup Generator  
Kenansville Elementary School Backup Generator  
Beulaville Elementary School Backup Generator  
North Duplin Elementary School Backup Generator

### Generalized Questions

Q: Will CATERPILLAR be accepted as a generator supplier?

A: Yes

Q: Would the county be interested in a 10-year warranty on the generator?

A: *If you wish for this to be considered, please provide this option as an alternate bid, or a separate non-required option.*

Q: Are there official bid forms for the project?

A: *No, the choice of format is yours. However, please refer to the bid packet for requirements.*

### Rose Hill-Magnolia Elementary School Backup Generator

Q: Specs state the Enclosure Material shall be steel construction. Plans show Aluminum construction. Which is correct? Based on the location we recommend Steel. Also, the specs call for a weatherproof Enclosure only. Plans note Weatherproof and sound attenuated. Which is correct? We suggest Sound attenuation on the enclosure.

A: *A steel housing with stainless steel hinges is allowable. A Level II sound attenuating housing is required.*

Q: Specs state a 48-hour base tank. Plans state 96-hour and 48-hour base tank. Which is correct?

A: *A 48-hour base tank is correct.*

### Kenansville Elementary School Backup Generator

Q: Specs state the Enclosure Material shall be steel construction. Plans show Aluminum construction. Which is correct? Based on the location we recommend Steel. Also, the specs call for a weatherproof Enclosure only. Plans note Weatherproof and sound attenuated. Which is correct? We suggest Sound attenuation on the enclosure.

A: *A steel housing with stainless steel hinges is allowable. A Level II sound attenuating housing is required.*



Q: Specs state a 48-hour base tank. Plans state 96-hour and 48-hour base tank. Which is correct?

A: *A 48-hour base tank is correct.*

Q: When visiting the site, it was discovered that PNL ND2 did not exist on the N Duplin Lift Station. Please clarify where the 120V will be picked up from the required circuits on the generator.

A: *It was intended that ND2 was a new panel. The riser diagram on E102 specifically calls it out as new.*

#### **Beulaville Elementary School Backup Generator**

Q: Specs state the Enclosure Material shall be steel construction. Plans show Aluminum construction. Which is correct? Based on the location we recommend Steel. Also, the specs call for a weatherproof Enclosure only. Plans note Weatherproof and sound attenuated. Which is correct? We suggest Sound attenuation on the enclosure.

A: *A steel housing with stainless steel hinges is allowable. A Level II sound attenuating housing is required.*

Q: Specs state a 48-hour base tank. Plans state 96-hour and 48-hour base tank. Which is correct?

A: *A 48-hour base tank is correct.*

Q: In the Base bid on the project can we propose to have the trash compactor relocated and install the new generator in the location on the existing compactor. When visiting the site there was multiple drains in the location of the proposed generator on the project. We are also assuming that all the Chiller lines are in that area as well. Are there as-builts of the site to show exiting conditions?

A: *We recommend submitting proposals for competitive bidding as defined by specifications and Engineer drawings.*

*Note: This change would be allowable by code. However, no as-built drawings are available. All costs and responsibility associated with the stated proposal would be the burden of the proposer/contractor. Duplin County Schools will without cost and as reasonably available in location of underground components.*

#### **North Duplin Elementary School Backup Generator**

Q: Specs state the Enclosure Material shall be steel construction. Plans show Aluminum construction. Which is correct? Based on the location we recommend Steel. Also, the specs call for a weatherproof Enclosure only. Plans note Weatherproof and sound attenuated. Which is correct? We suggest Sound attenuation on the enclosure.

A: *A steel housing with stainless steel hinges is allowable. A Level II sound attenuating housing is required.*

Q: Specs state a 48-hour base tank. Plans state 96-hour and 48-hour base tank. Which is correct?

A: *A 48-hour base tank is correct.*

Q: When visiting the site, it was discovered that PNL ND2 did not exist on the N Duplin Lift Station. Please clarify where the 120V will be picked up from the required circuits on the generator.

A: *It was intended that ND2 was a new panel. The riser diagram on E102 specifically calls it out as new.*



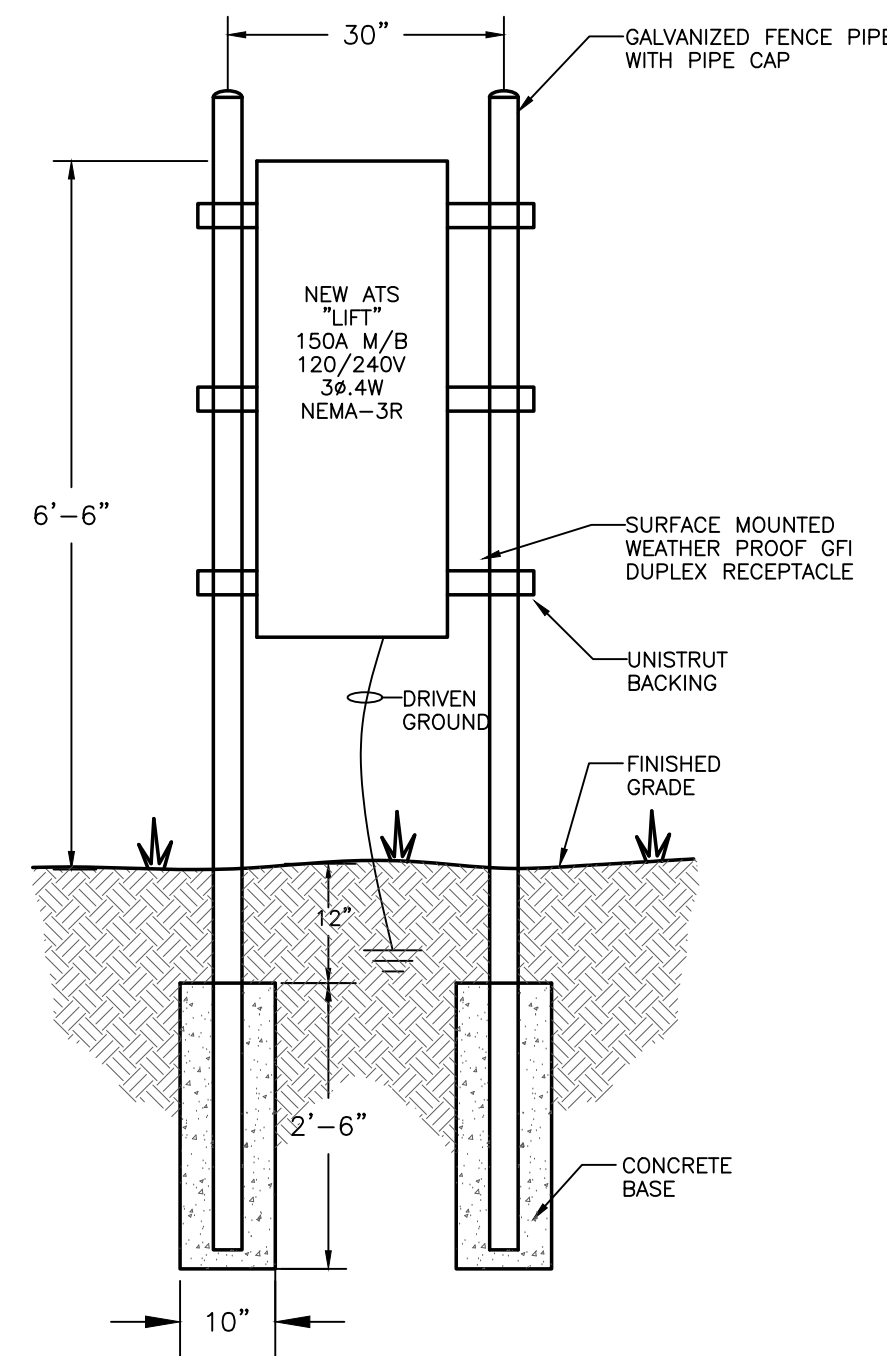

**STAND DETAIL**  
SCALE: NTS

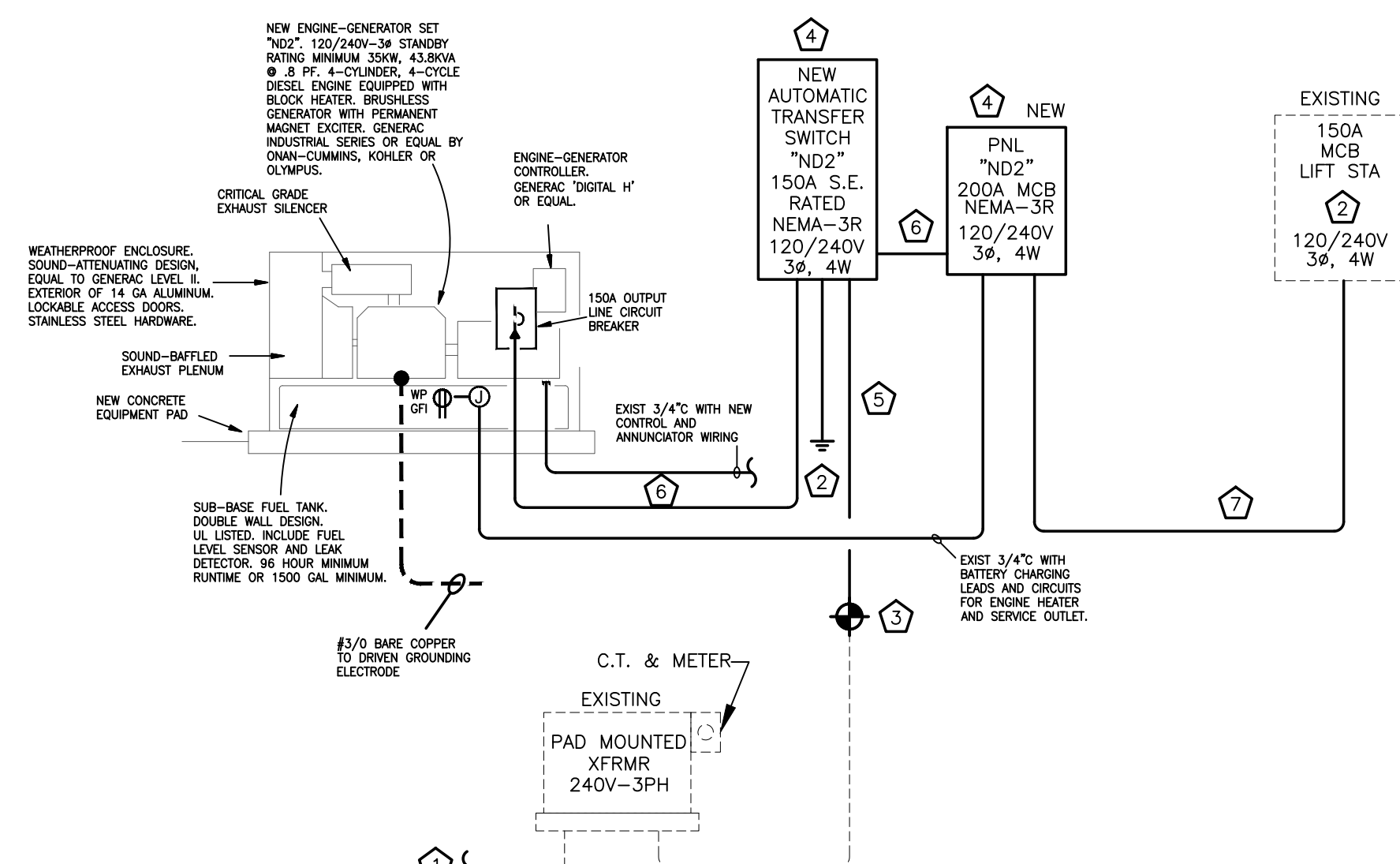

**102.1 LIFT STA. ELECTRICAL RISER**  
SCALE: NONE

**ELECTRICAL RISER NOTES:**

- 1 EXISTING UNDERGROUND SERVICE TO REMAIN
- 2 SERVICE ENTRANCE GROUND; SEE SERVICE GRND DETAIL. DISCONNECT THE EXIST JUMPER BETWEEN THE NEUTRAL BAR AND THE GRND BAR IN LIFT STA. PANEL.
- 3 E.C. TO INTERCEPT EXISTING WIRING FROM TRANSFORMER TO MAIN SWITCH AND INSTALL NEW ATS IN LINE AT APPROXIMATE LOCATION SHOWN ON PLANS.
- 4 MOUNT ATS AND GS2 ON RACK. SEE DETAIL.
- 5 4-#3/0 IN 2" C
- 6 4-#3/0 & 1-#8G IN 2" C
- 7 4-#1/0 & 1-#6G IN 2" C

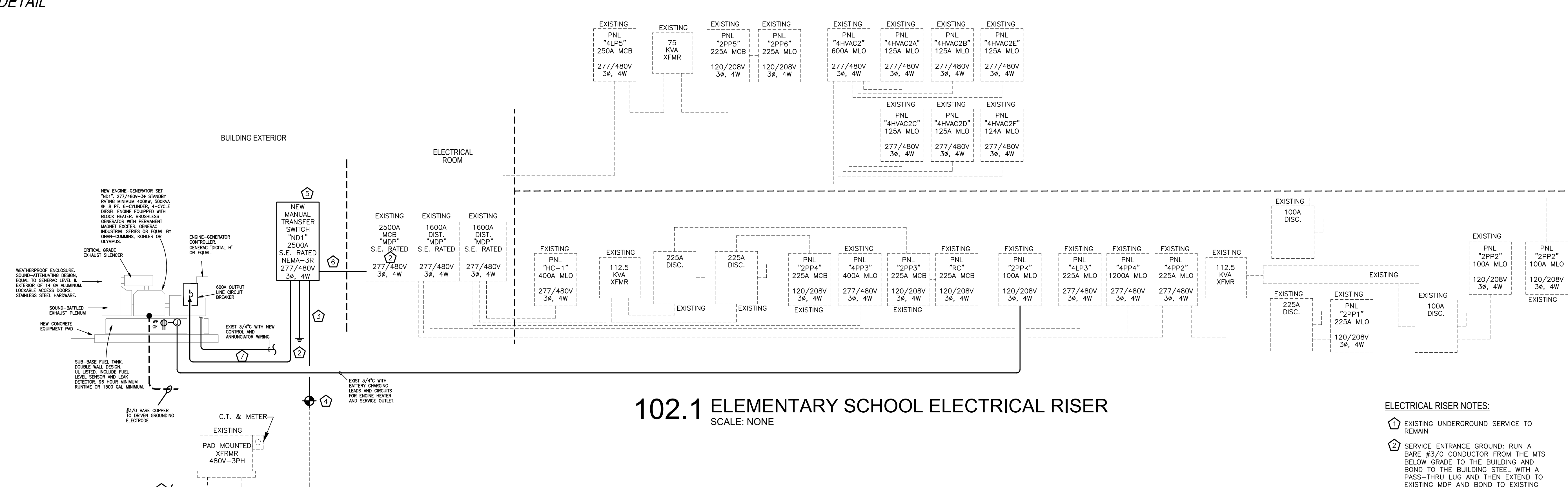

**102.1 ELEMENTARY SCHOOL ELECTRICAL RISER**  
SCALE: NONE

**ELECTRICAL RISER NOTES:**

- 1 EXISTING UNDERGROUND SERVICE TO REMAIN
- 2 SERVICE ENTRANCE GROUND; RUN A BARE #3/0 CONDUCTOR FROM THE MTS BELOW GRADE TO THE BUILDING AND BOND TO THE BUILDING STEEL WITH A PASS-THRU LUG AND THEN EXTEND TO EXISTING MDP AND BOND TO EXISTING SERVICE GROUNDING SYSTEM. DISCONNECT THE EXIST JUMPER BETWEEN THE NEUTRAL BAR AND THE GRND BAR IN THE MDP.
- 3 E.C. TO INTERCEPT EXISTING WIRING FROM TRANSFORMER TO MAIN SWITCH AND INSTALL NEW MTS IN LINE AT APPROXIMATE LOCATION SHOWN ON PLANS.
- 4 MOUNT MTS ON BUILDING AS INDICATED AND FEED THROUGH WALL TO MDP.
- 5 6 SETS: 3-#600KCMIL IN 4" C BELOW GRADE. REUSE EXIST. CONDUIT AS MUCH AS POSSIBLE.
- 6 6 SETS: 3-#600KCMIL & 1-#3/0G IN 4" C
- 7 3 SETS: 4-#3/0 & 1-#1G. ON 2.5" C

**ENGINE - GENERATOR SYSTEM (ELEMENTARY SCHOOL):**

ENGINE-GENERATOR SET SHALL BE GENERAC OR EQUAL BY ONAN-CUMMINS OR KHOLER.  
 MIN STANDBY RATING AS SHOWN ON RISER DIAGRAMS WITH 277/480V THREE PHASE 4-WIRE OUTPUT.  
 PROVIDE WITH DIESEL DRIVEN ENGINE WITH A 48 HOUR RUN TIME BELLY TANK, 1,200 GAL. MINIMUM.  
 4 OR 6 CYLINDER 4 CYCLE ENGINE, RADIATOR COOLED, INCLUDE JACKET WATER HEATER WITH T'STAT. ENGINE CONTROL PANEL WITH AUTOMATIC SHUT-DOWNS ON OVER-TEMPERATURE, LOW OIL PRESSURE, ETC. HEAVY DUTY BATTERIES, HI-LO RATE AUTOMATIC CHARGER SYSTEM.  
 ALTERNATOR SHALL BE BRUSHLESS ROTATING FIELD TYPE, WITH PERMANENT MAGNET EXCITATION SYSTEM. WINDINGS SHALL BE VACUUM-IMPREGNATED WITH FUNGUS-RESISTANT EPOXY VARNISH.  
 UNIT SHALL BE PROVIDED WITH WEATHERPROOF HOUSING, HOUSING SHALL BE OF HEAVY-GAUGE ALUMINUM, WITH STAINLESS STEEL HARDWARE. HOUSING SHALL BE DESIGNED FOR SOUND ATTENUATION, WITH RADIATOR AND CRITICAL GRADE SILENCER INTERNALLY MOUNTED AND BAFLED.  
 MANUAL TRANSFER SWITCH SHALL BE ASCO OR EQUAL FOR GENERATOR MANUFACTURER. SWITCH SHALL BE FOR 277/480V THREE-PHASE FOUR-WIRE OPERATION, RATED 2,500A AS A MINIMUM. UL LABEL FOR SERVICE ENTRANCE USE. SERVICE ENTRANCE BREAKER SHALL BE SEPARATE FROM SWITCH OVER CIRCUIT BREAKER DISCONNECTS FOR NORMAL AND EMERGENCY INCOMING FEEDS. 3-POLE TRANSFER, WITH SOLID NEUTRAL, RATED FOR USE ON SYSTEM WITH AVAILABLE FAULT CURRENT OF 43,000A. EQUIP WITH INTEGRAL SURGE SUPPRESSION DEVICE.  
 MICROPROCESSOR CONTROL INCLUDING ADJUSTABLE TIME DELAYS ON ENGINE START, TRANSFER, RE-TRANSFER, AND SHUT-DOWN. AUTOMATIC EXERCISE CONTROL, WITH SELECTOR SWITCH FOR LOAD OR NO-LOAD TEST. SYNC-CHECK RELAY FOR TRANSFER IN EITHER DIRECTION. MANUAL OPERATING LEVER. ENCLOSURE SHALL BE NEMA 3R RATED STEEL, EQUIP WITH HEATER AND T'STAT. ON FRONT OF ENCLOSURE, PROVIDE LED PILOT LIGHTS INDICATING SWITCH STATUS, AND EMERGENCY SHUT-DOWN PUSH-BUTTON.

BRANCH CIRCUIT AND CONDUIT BY ELECTRICAL CONTRACTOR. SEE PANELBOARD SCHEDULES FOR WIRE AND BREAKER SIZES FOR HVAC AND PLUMBING EQUIPMENT. HVAC AND PLUMBING CONTRACTOR SHALL BE RESPONSIBLE FOR COORDINATING ANY WIRE AND BREAKER SIZE CHANGES WITH ELECTRICAL CONTRACTOR.

EXTERNALLY OR INTERNALLY MOUNTED DISCONNECT SWITCH FURNISHED BY MECHANICAL, PLUMBING, OR OTHER CONTRACTORS, AND INSTALLED BY ELECTRICAL CONTRACTOR. MECHANICAL, PLUMBING, AND OTHER CONTRACTORS SHALL PROVIDE FUSES, AS REQUIRED.

EXTERNALLY MOUNTED STARTER FURNISHED BY MECHANICAL, PLUMBING, OR OTHER CONTRACTORS, AND INSTALLED BY ELECTRICAL CONTRACTOR. LINE AND LOAD SIDE CONNECTIONS BY ELECTRICAL CONTRACTOR. CONTROLS CONNECTIONS BY OTHER.

EQUIPMENT BY OTHERS

EQUIPMENT BY MECHANICAL, PLUMBING, OR OTHER CONTRACTORS. SEE MECHANICAL, PLUMBING, AND ARCHITECTURAL PLANS FOR LOCATION OF ALL EQUIPMENT.

A COMBINATION STARTER MAY BE USED IN LIEU OF A SEPARATE DISCONNECT SWITCH AND STARTER.

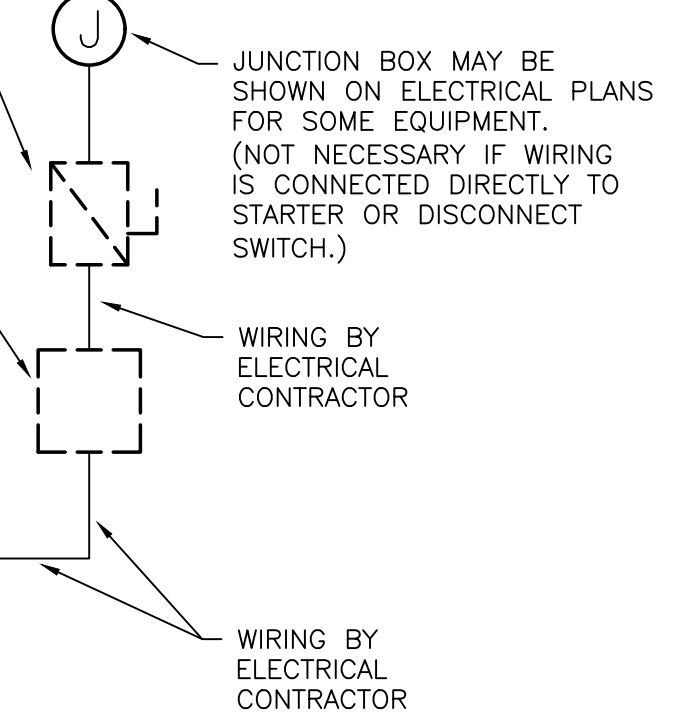

**GENERATOR EQUIPMENT PAD**  
SCALE: N.T.S.

SEISMIC INFORMATION:  
 RISK CATEGORY: III  
 SEISMIC IMPORTANCE FACTOR: 1.25  
 MAPPED RESPONSE (S<sub>s</sub> AND S<sub>1</sub>): 16.8%g & 7.8%g  
 SITE CLASS: D  
 DESIGN RESPONSE (S<sub>ds</sub> AND S<sub>d1</sub>): 17.9%g & 12.6%g  
 SEISMIC DESIGN GROUP: B

**102.3 ELECTRICAL CONNECTION DETAIL**  
SCALE: NONE

Hite associates  
 ARCHITECTURE / PLANNING / TECHNOLOGY  
 2600 Meridian Drive / Greenville, NC 27834 / Tel (252) 757-0333

Generator Addition  
 NORTH DUPLIN ELEMENTARY  
 157 NORTH DUPLIN SCHOOL RD  
 MT. OLIVE / North Carolina

Project No: ES21068  
 Date: March 2022  
 Drawing No: E 102

**RELATED DOCUMENTS:**

Drawings and general provisions of Contract, including General and Supplementary Conditions and Division-1 Specification sections, apply to work of this section.

**SCOPE OF WORK:**

The scope of work consists of the furnishing and installing of complete electrical systems including miscellaneous systems. The Electrical Contractor (hereafter referred to as "the Contractor", or Electrical Contractor) shall provide all supervision, labor, materials, equipment, machinery, and any and all other items necessary to complete the systems. The Contractor shall note that all items of equipment are specified in the singular; however, the Contractor shall provide and install the number of items of equipment as indicated on the drawings and as required for complete systems.

It is the intention of the Specifications and Drawings to call for finished work, tested and ready for operation.

Any apparatus, appliance, material, or work not shown on the drawings but mentioned in the specifications, or vice versa, or any incidental accessories necessary to make the work complete and perfect in all respects and ready for operation, even if not particularly specified, shall be furnished, delivered, and installed by the Contractor without additional expenses to the Owner.

Minor details not usually shown or specified, but necessary for proper installation and operation, shall be included in the Contractor's estimate, the same as if herein specified or shown.

With submission of bid, the Contractor shall give written notice to the Architect of any materials or apparatus believed inadequate or unsuitable, in violation of laws, ordinances, rules, and any necessary items or work omitted. In the absence of such written notice, it is mutually agreed that the Contractor has included the cost of all required items in his proposal, and that he will be responsible for the approved satisfactory functioning of the entire system without extra compensation.

NOTICE TO BIDDERS, INSTRUCTIONS TO BIDDERS, SUPPLEMENTARY INSTRUCTIONS, GENERAL CONDITIONS, SUPPLEMENTARY GENERAL CONDITIONS, SPECIAL CONDITIONS, GENERAL REQUIREMENTS bound in the front of this document are included as a part of the specifications for this work.

**ELECTRICAL DRAWINGS AND SPECIFICATIONS:**

The electrical drawings are diagrammatic and indicate the general arrangement of fixtures, equipment, and work included in the contract. Consult the architectural, structural, plumbing, fire alarm, integrated communications, and mechanical drawings and details for exact locations and dimensions of fixtures and equipment; where same are not definitely located, obtain this information from the Architect.

The Contractor shall follow drawings in laying out work and check drawings of other trades to verify spaces in which work will be installed. Maintain maximum headroom and space conditions at all points. Where headroom or space conditions appear inadequate, the Architect shall be notified before proceeding with installation. If directed by the Architect, the Contractor shall, without extra charge, make reasonable modifications in the layout as needed to prevent conflict with work of other trades or for proper execution of the work.

The plans and these specifications are intended to describe, imply and convey the materials and equipment as well as necessary labor, required for the installation as outlined in the paragraph entitled "Scope of Work". Any omissions from either the drawings or these specifications are unintentional, and it shall be the responsibility of this Contractor to call to the attention of the Architect or Engineer any pertinent omissions before submission of a bid. The drawings which accompany these specifications are not intended to show in complete detail every fitting which may be required; however wherever reasonable implied by the nature



of the work, any such material or equipment shall be installed by this Contractor as a part of his contract price. In no case will any extra charge be allowed unless authorized in writing by the Architect or Engineer.

The Contractor shall arrange with the General Contractor for required concrete and masonry chases, openings, and sub-bases so as not to delay progress of work. Work shall be installed sufficiently in advance of other construction to conceal piping and to permit work to be built in where required.

It shall be understood and agreed by all parties that where the words "Furnish", "Install", and / or "Provide" appear, the following definitions apply:

Furnish - to supply or give.

Install - to place, establish or fix in position.

Provide - to furnish and install as defined above.

**CODES, PERMITS, AND FEES:**

The Contractor shall give all necessary notices, including electric and telephone utilities, obtain all permits, and pay all government taxes, fees, and other costs, including utility connections or extensions in connection with his work file all necessary plans, prepare all documents, and obtain all necessary approvals of all governmental departments having jurisdiction at each phase of construction as required; obtain all required certificates of inspection for his work and deliver same to the Architect before request for acceptance and final payment for the work.

The Contractor shall include in the work, without extra cost to the Owner, any labor, materials, services, apparatus, drawings (in addition to contract drawing and documents) in order to comply with all applicable laws, ordinances, rules, and regulations, whether or not shown on drawings and / or specified.

All work and materials under this section shall be in strict compliance with more stringent requirements of the North Carolina State Building Code, including the National Electrical Code, NFPA 101-Life Safety Code, Regulations of the State Fire Marshall, UL Directory of Electrical Construction Materials, and requirements of the local utility company.

**VERIFICATION OF DIMENSIONS, DETAILS, EXISTING FIELD CONDITIONS:**

The Contractor shall visit the premises prior to bidding, and thoroughly familiarize himself with all details of the work, working conditions, verify dimensions in the field, provide advice of any discrepancy, and submit shop drawings of any changes he proposes to make in quadruplicate for approval before starting any work. The Contractor shall install all equipment in a manner to avoid building interference.

**COORDINATION WITH EQUIPMENT PROVIDED BY OTHERS:**

Electrical contractor shall coordinate voltage, phase and amperage requirements for all Plumbing, HVAC, and Kitchen equipment with the sub-contractor providing the equipment prior to ordering electrical gear submittals. Make adjustments to panels, feeders, and breakers as necessary to feed actual equipment being provided. Make engineer/architect aware of any conflicts or issues.

**ACCEPTABLE MANUFACTURERS:**

Acceptable manufacturers, as specified in the Contract Documents, implies that the specified manufacturer may produce acceptable products equal in quality of materials and performance to such item specified. The Contractor will be required to provide products meeting or exceeding the "Standard of Quality and Performance" as dictated by the product selection noted. However, any changes which result (from substitution of other manufacturers) in the electrical work or work of other Contractors, shall be paid for by the Contractor.

**SHOP DRAWINGS:**

The Contractor shall submit five (5) copies of the shop drawings to the Architect for approval within thirty (30) days after the award of the general contract. If such a schedule cannot be met, the Contractor may request in writing for an extension of time to the Architect. If the Contractor does not submit shop drawings in the prescribed time, the Architect has the right to select the equipment.

Provide manufacturer's cuts of items to be provided under this Contract. Included, but not limited to these items, are any of the following which may be required in this Contract: Fixtures, switches, outlet boxes, device plates, panelboards, transformers, conductors, pull boxes, wiring troughs, circuit breakers, disconnect switches, emergency fixtures, receptacles, etc.

The shop drawings shall be neatly bound in five (5) sets and submitted to the Architect with a letter of transmittal. The letter of transmittal shall list each item submitted along with the manufacturer's name.

Approval rendered on shop drawings shall not be considered as a guarantee of measurements or building conditions. Where drawings are approved, said approval does not mean that drawings have been checked in detail; said approval does not in any way relieve the Contractor from his responsibility or necessity of furnishing material or performing work as required by the contract drawings and specifications.

**COORDINATION WITH OTHER TRADES:**

Coordinate all work required under this section with work of other sections of the specifications to avoid interference. Bidders are cautioned to check their equipment against space available as indicated on drawings and shall make sure that proposed equipment can be accommodated. If interferences occur, Contractor shall bring them to attention in writing, prior to signing of contract; or, Contractor shall at his own expense provide proper materials, equipment, and labor to correct any damage due to defects in his work caused by such interference.

**INSPECTION AND CERTIFICATES:**

On the completion of the entire installation, the approval of the Architect and Owner shall be secured, covering the installation throughout. The Contractor shall obtain and pay for Certificate of Approval from the public authorities having jurisdiction. A final inspection certificate shall be submitted to the Architect prior to final payment. Any and all costs incurred for fees shall be paid by the Contractor.

**EQUIVALENTS:**

When material or equipment is mentioned by name, it shall form the basis of the Contract. When approved by the Architect in writing, other material and equipment may be used in place of those specified, but written application for such substitutions shall be made to the Architect as described in the Bidding Documents. The difference in cost of substitute material or equipment shall be given when making such request. Approval of substitute is, of course, contingent on same meeting specified requirements and being of such design and dimensions as to comply with space requirements.

**EXCAVATING AND BACKFILLING FOR ELECTRICAL WORK:** Refer to Sections 02202 & 02220.

**CUTTING AND PATCHING:**

On new work, the Electrical Contractor shall furnish sketches to the General Contractor showing the locations and sizes of all openings and chases, and furnish and locate all sleeves and inserts required for the installation of the electrical work before the walls, floors, and roof are built. The Electrical Contractor shall be responsible for the cost of cutting and patching where any electrical items were not installed or where incorrectly sized or located. The Contractor shall do all drilling required for the installation of his hangers. See also Section 01050.

*END OF SECTION*

**RELATED DOCUMENTS:**

Drawings and general provisions of Contract, including General and Supplementary Conditions and Division-1 Specification sections, apply to work of this section.

**CONDUIT SYSTEM:**

Furnish and install all conduits, or other raceways, fittings, boxes, and other component parts specified or required for completion and proper operation of the conduit system shown on the drawings.

Other than as noted above, conduit shall be sized in accordance with the 2005 NEC. All conduit shall be neatly installed parallel to, or at right angles to beams, walls and floors of the building in a neat and workmanlike manner. All bends shall be made with standard conduit elbows or conduit bent to not less than the same radius as that of a standard conduit elbow. Conduits shall be supported at intervals not greater than 8' and within 3' of any bend, cabinet, outlet or junction box. Conduits shall be supported by approved pipe straps or clamps, secured by means of toggle bolts on hollow masonry, expansion shields and machine screws or standard pre-set inserts on concrete or solid masonry, machine screws or bolts on metal surfaces, and wood screws on wood construction.

Conduit 1/2" (minimum) and larger shall be electrical metallic tubing (EMT). EMT shall be cold-rolled steel tubing with a coating on the outside and protected on the inside by a zinc, enamel, or equivalent corrosion-resistant coating and conforming to the requirements of ANSI C 80.3-1966 or later edition. EMT may be installed in dry construction in furred spaces, in partitions other than concrete and solid plaster, or for exposed work except on mechanical structures or supports, or in refrigerated areas. EMT shall not be installed where: it will be subject to physical damage; where it will be installed nearer than 4' from finished floor in exposed areas; where it will be subject to severe corrosive influence; where the trade size is larger than 2"; or where tubing, elbows, couplings, and fittings would be in concrete or indirect contact with the earth. Electric metallic tubing fittings shall be all plated steel hexagonal threaded compression type, with insulated throats. No pot metal, set screw, or indenter fittings shall be used.

Connections to lighting fixtures will be permitted with flexible steel conduit strapped every 6'-0", with UL listed AC type cables, used in strict accordance with 2005 NEC Article 333. Armored Cable assembly shall encase conductors in a continuous length of galvanized cold rolled steel strip, spirally wound with adjacent strips locked to turn all edges inward. The ends shall be terminated with fiber bushings to protect conductors from sharp edges. Fittings shall be the insulated throat type, T & B 3100 series or equivalent.

All underground conduit shall be UL Listed Schedule 40 PVC conforming to Article 347 of the 2005 NEC, or rigid galvanized steel. At the Contractor's option, this installation may consist of rigid steel conduit with PVC coating, minimum of 15 mils of PVC. Where schedule 40 PVC is installed under floor slabs, the elbows required to turn the raceway up into cabinets, equipment, etc., shall be of rigid steel. A copper ground wire shall be installed in all PVC conduits. PVC conduit shall not be used above the floor slab, unless roughed-in masonry wall.

All exposed conduit to 5'- 0" above finish floor shall be rigid galvanized steel or IMC conduit. Liquid-tight flexible steel conduit with an extruded PVC jacket shall be used for connections to exterior motors and compressors. Liquid-tight flexible conduit fittings shall be insulated throat type, Appleton STB type or equal.

All permanent conduit stub-outs shall be sealed with galvanized standard water pipe caps immediately after installation. All conduits crossing expansion joints shall have approved type expansion fittings as manufactured by Crouse Hinds, Killark or Appleton. Fittings shall be of type to ensure ground continuity. Provide a 240 lb. tensile strength poly pull-wire in all empty conduits.

**OUTLETS AND PULL BOXES:**

All boxes shall be UL labeled or listed by an approved agency. At each location where required, an outlet box of a type to suit the intended use shall be installed. Boxes shall be fastened to building structure in an approved manner. Flush outlet, junction and pull boxes shall be pressed galvanized or sheradized steel, either square or octagonal with knockouts on tops and sides, and fitted with plaster covers where necessary to set flush with the finished surface. For use in hollow-core masonry walls, switch boxes shall be of sufficient depth to permit conduit to rise in the core with minimum cutting of block. Provide plaster rings or box extensions for flush devices with finish surface. Boxes for unplastered masonry walls shall be masonry type with device mounting ears on the interior of the box.

Convenience outlet boxes shall be generally mounted approximately 18" above floor, 48" above floor in mechanical equipment rooms and shop type areas, and 4" above counter backsplash, unless otherwise noted. Convenience outlets for drinking fountains shall be installed behind fountain enclosure so as not to be visible; coordinate with Plumbing Contractor.

Lighting switch outlet boxes shall be 4' above floor, unless noted or required otherwise. Where switches occur in 4' high tile walls, they shall be lowered by 6 inches.

Pull boxes shall be used as required in long runs of conduit to facilitate pulling of wires. All interior pull boxes shall be constructed of code gauge galvanized sheet metal, and not less than the minimum size recommended by the NEC. Boxes shall be furnished with screw-fastened covers. When several feeders pass through a common pull box they shall be tagged to indicate clearly their electrical characteristics, circuit number, and panel designation. Wire markers shall be as manufactured by W. H. Brady Co., or equal. In no case shall a pull box be installed in an inaccessible location. Boxes shall be provided with fixed or removable steel barriers for each circuit where two or more feeders pass through the box. In case of banked conduit runs consisting of more than two horizontal rows of conduits, where barriers would be impracticable, the cables for each conduit shall be tied together with heavy waxed twine and wrapped with one wrap of heavy grade tape.

Where two or more outlets are to be installed in one location, they shall be installed in gang boxes suitable for the intended purpose.

Outlet boxes for outdoor use, and for exposed use where not covered by fixture canopies, shall be cast metal suitable for the intended purpose, having integral threaded hubs, and of the weatherproof type with gasket. Provide special outlet boxes where indicated.

All junction boxes shall be marked with panel and circuit number which it contains.

*END OF SECTION*

**RELATED DOCUMENTS:**

Drawings and general provisions of Contract, including General and Supplementary Conditions and Division-1 Specification sections, apply to work of this section.

**CONDUCTORS FOR 600 VOLTS OR LESS:**

All conductors shall be copper with a minimum conductivity of 98% and shall be delivered to the job site in their original packages, marked or tagged as follows : UL label , size, type, and insulation of the wire; name of manufacturer and trade name of the conductor: and date of manufacture. All conductors shall be insulated for 600 volts unless otherwise indicated. Furnish and install all conductors specified or required for completion and proper operation of the various systems shown on the drawings.

Conductors shall be 600 volt type THW or THWN. Branch circuit conductor shall not be smaller than No. 12 AWG, except where specifically noted otherwise. Home runs originating more than 80' at 120 volts from panel location shall be No. 10 AWG minimum size. Wires No. 10 AWG and smaller shall be solid; wires No. 8 AWG and larger shall be stranded. Where branch circuits are fed through fluorescent fixture channels, use code grade type THHN or XHHW. All AC cables where permitted shall include a separate copper ground conductor sized per phase conductors.

Provisions of Section 210-5, Color Code, NEC, shall be strictly complied with. Color coding shall include feeders and mains and be consistent throughout entire system. For 120/208 volt systems, use black, red, and blue for phases A, B, & C respectively. For 277/480 volt systems, use brown, orange, and yellow for phases A, B, & C respectively.

All conductors in vertical raceways shall be properly supported at intervals not greater than those specified in Section 300-19 of NEC.

All wire and cable except as specifically stated otherwise, shall be of one of the following makes: Anaconda Wire and Cable Co., General Cable Corp., General Electric Co., or Okonite Co.

**JOINTS AND CONNECTIONS:**

The Engineer reserves the right to inspect any and all joints made in wiring. If they are taped prior to being inspected, the tape shall be removed as ordered from any joint or joints for inspection. After inspection and correction of any fault found, the Contractor shall properly retape the joints.

Conductors shall be continuous without joints or splices in runs between outlet boxes. All splices shall be made at boxes only. Where stranded conductors are to be connected to any apparatus, bus work, switches or fuse blocks, they shall be connected by suitable mechanical solderless type lugs or spades. All lugs shall be permanently bolted in such position as to give maximum contact surface available. Where multiple circuits are run from same switch or panel, individual lugs for each conductor shall be used. Feeder taps in junction boxes or panel gutter shall be made with insulated cover panel gutter taps. Feeder conductors shall not be spliced, feeder conductors shall be continuous for the length of run.

Solid conductors, namely those sized #10 and #12 AWG copper, shall be spliced by using Ideal "wire-nuts", 3M Co. "Scotchlok", or T & B "Piggy" connectors for branch circuit splices in junction boxes and light fixtures, except recessed fixtures as noted above. "Sta-Kon" or other other permanent type crimp connectors shall not be used.

Stranded conductors, namely #8 AWG copper and larger, shall be spliced by approved mechanical connectors plus gum tape, plus friction or plastic tape. Solderless mechanical connectors, for splices and taps, provided with UL approved insulating covers, may be used instead of mechanical connectors plus tape.

**DEVICE PLATES:**

A device plate shall be provided for each outlet to suit the device installed. All plates shall be no. 302 stainless steel construction. All plates shall be "jumbo" size.

Device plates shall be of the one piece type, of suitable shape for the devices to be covered. The use of sectional device plates will not be permitted. Plates having a .375" bushed hole in the center shall be installed on all wall mounted outlets for telephones.

Devices and/or plates installed prior to painting shall be properly taped and shall be cleaned after painting, if necessary. Blank plates shall be installed on all unused outlets.

Plates shall be manufactured by Pass & Seymour, Bryant, or Hubbell. Provide sample of plates to Architect for approval.

**RECEPTACLES:**

Duplex convenience outlets for general use shall be rated 20 amperes, 125 volts, duplex, for standard parallel blade three-wire grounded type caps, Hubbell No. 5362-I (ivory), Leviton, Pass & Seymour or Arrow-Hart or approved equal. Color to be selected by Architect. Where outlets are installed vertically, ground plug position shall be on top and on right side where outlets are installed horizontally.

**SPECIAL USE RECEPTACLES:**

Provide special receptacles including receptacles with ground fault circuit interrupter protection, where needed, as required by equipment. Provide MOV-based transient voltage surge suppression devices (SS), where shown on plan. Tamper-resistant receptacles (TP) shall prevent insertion of objects other than a properly rated 2 or 3 wire plug using "floating" shutters. Equal devices by Hubbell, Leviton, Pass & Seymour or Arrow-Hart are considered acceptable.

**WALL SWITCHES:**

Wall switches shall be installed as shown on the drawings and shall be connected to provide control of the outlets indicated. Switches shall be rated at 20 amperes for 120 volts or 277 volts lighting circuits. Hubbell No. 1221 (or 1221-1), for single pole; Hubbell Catalog No. 1223 (or 1223-1) for 3-way; Hubbell Catalog No. 1224 (or 1224-1) for 4-way. Weather-proof switches shall be Hubbell No. 1781 single pole or Hubbell No. 1783 3-way. Provide sample of switches to Engineer for approval. Color of switches to be selected by Architect.

Automatic light switches shall have passive infra-red occupancy switch with light sensor to prevent light from switching on when daylight is above pre-set level. Switch shall be UL listed, have adjustable time delay of 30 seconds to 30 minutes, auto/off control, and minimum coverage of 900 square feet, Automatic light switch shall be UNENCO model no. D-IS.

Provide special purpose switches where noted on the drawings, or elsewhere. Equal devices by Pass & Seymour or Arrow-Hart are considered acceptable.

For wall switches indicated as dimmers on LED lighting, coordinate the exact 0-10 volt dimmer that is compatible with LED driver at 277V for the specific fixtures provided. Install the correct size wall box to accommodate the specific dimmer to be installed.

*END OF SECTION*

**SERVICE EQUIPMENT AND POWER DISTRIBUTION:**

Furnish, install and completely connect the circuit breaker type service, panelboard and distribution equipment as indicated. All construction shall meet applicable standards of ANSI, IEEE, and NEMA, and all equipment shall bear UL label insofar as it is available. Equipment shall be Square D QED, I-Line or QMB; equipment manufactured by Cutler-Hammer (Eaton) , General Electric, or ITE Siemens will be considered equal.

Provide a copper bus interior with and insulated neutral in the Main Distribution Panel. This neutral bus shall be the source for all insulated neutral conductors of the system. Jumpers shall be installed to connect the insulated neutral bus to the uninsulated grounding bus. The uninsulated grounding bus shall be the source of grounds for all grounding and bonding (not neutrals) of equipment.

Electrical contractor is responsible for providing all transformer and equipment data to gear supplier as necessary for the supplier to evaluate and coordinate any circuit breaker settings to ensure that downstream breakers trip prior to any upstream breakers.

**LIGHTING AND POWER PANELBOARDS:**

Panelboards shall be of the thermal-magnetic circuit-breaker type and shall consist of an assembly of single, double, and triple-pole breakers. Each circuit-breaker shall be bolted-in, removable without disturbing the adjacent units and shall have trip ratings as indicated. All multipole breakers shall be common trip. Ground fault circuit breakers shall be used as indicated on the drawings.

Each panelboard shall be installed in an appropriate cabinet of sufficient size with top 6'- 0" above finish floor and shall conform to the requirements of UL standard for cabinets and boxes. Standard cabinets with surface or flush type trim and door shall be used, as required. Cabinets shall have a minimum width of 20" unless noted otherwise. A neutral bar shall be provided in each panel with a terminal for each breaker. Grounding lugs shall be provided.

Cabinet shall be made of spot welded galvanized sheet steel not less than N.E.C. gauge with hinged door and trim of the same material. When closed, the door shall fit accurately in the opening provided and present a flush finish with the trim. The door shall be equipped with a key operated lock. Furnish one key with each lock. All door locks shall be keyed alike. Knockouts in cabinets are not acceptable. Cabinets shall be finished with manufacturer's standard painted finish.

On the inside of each door, a typewritten directory identifying each circuit shall be mounted in a suitable protective enclosure. Panelboards shall have laminated plastic designations on inside corresponding to feeder and drawing identifications.

Panelboards shall be Square D I-Line or NQOD Series or equal by Cutler-Hammer, General Electric, or Siemens.

**SHUNT TRIP PROTECTION:**

All electrical equipment located under a kitchen hood with a fire suppression system shall be protected by a shunt trip device that is interlocked with the suppression system. Upon activation of the suppression system the shunt device shall trip and disconnect power for the equipment under the hood. This may be done via individual shunt trip breakers or a single main breaker that is shunted upon activation of the suppression system. If a main shunt breaker is utilized no circuits should be fed from the respective distribution panel other than the circuits for the equipment under the hood. Elevator feeder circuits shall also be protected by a shut trip device if the elevator shaft and/or the elevator equipment room are protected by a fire suppression system. Coordinate with the General Contractor for final plans from the Sprinkler Design-Build Contractor.

**SURGE PROTECTION:**

Furnish and install transient voltage surge suppressor (TVSS) units where indicated on the drawing risers as 'SP' to protect AC electrical circuits from the detrimental effects of lightning, utility switching transients, AC motor transients, and other internal generated transients. TVSS shall comply with UL 1449, have a Category C pulse life for all protection modes (L-N, L-G or L-L where applicable), shall operate bio-directionally, and shall have a maximum single pulse current capacity of 50 KA per mode in accordance with NEMA LS1-1992. Acceptable manufacturers include Leibert, Current Technology, LEA, and United Power. Provide complete shop drawing submittal including installation instructions, dimensional drawings, clamp voltage data, and 3rd party data confirming single pulse current capacity rating. Provide on-site manufacturer's testing and start-up.

**SAFETY DISCONNECT SWITCHES:**

Disconnect switches shall be horsepower rated, installed where indicated and / or required by the NEC. Switches, except where shown as beined by other sections shall be furnished under this Section. Switches shall be heavy duty, fused unless otherwise noted, sized as shown, quick-make, quick-break, NEMA type "ND" with NEMA 1 enclosure, type HD, Square D. Switches to be installed outdoors shall be NEMA type 3R, with raintight conduit hubs. All switches shall be capable of being locked in the "off" position. Fuses shall be one-time, non-renewable types, dual-element, time-delay, Bussman or equal as required for application.

**MOTOR STARTERS:**

Motor controllers shall, unless otherwise specifically noted, be combination magnetic type, with thermal overload relays and heaters in each phase conductor, with operating coils for 120 volts as noted on the drawings or as required. Maximum trip rating of starters for hermetic motors shall be at least 105% of the nameplate full load current of the motor.

Starters shall be provided with build-in selector switches (H-O-A) or pushbutton stations where required. Combination starters shall be provided with sufficient auxiliary contacts or control relays for control sequence as specified, indicated or as required, and with sufficient auxiliary contacts on its circuit breaker or with control relays so that opening the circuit breaker ahead of the starter unit opens all hot control lines within the starters. All starters furnished under this Section shall be mounted in individual NEMA 1 enclosures, unless otherwise specified or indicated on drawings. Special requirements are specified in the separate Sections of this Division or indicated on the drawings.

**LIGHTING CONTACTORS:**

Each lighting contactor shall have heavy-duty ballast load rated contacts. Each contactor shall have mechanically held contacts, and silver cadmium oxide double break contacts. Contacts shall be field convertible with normally open and normally closed indicators. Each contactor shall be UL listed and CSA certified. All new lighting contactors for each new building shall be housed in a properly sized NEMA-1 enclosure with fully hinged and lockable door.

**FIRE ALARM & HVAC CONTROLS:**

Electrical contractor is responsible for all conduit and wiring required to power any fire alarm control or booster panels, magnetic door holders, and the HVAC Building Automation Controls system cabinets. There shall be at least (2) Fire Alarm and (2) HVAC control system circuits per wing of the school. Coordinate exact location and quantity of cabinets with Fire Alarm and Mechanical's Controls Sub-Contractor. Termination to Fire Alarm and HVAC controllers and to HVAC equipment shall be by controls contractor. Electrician shall use 1P-20A circuits designated as Fire Alarm or HVAC Controls on panel schedules or the closest available spare 1P-20A (120V) breakers for powering the controls system. Notify Engineer if circuits were not indicated and update panel directories on Record Drawings.



**GROUNDING:**

Provide a bare stranded continuous copper grounded conductor, size as indicated, from the service equipment grounding bus to the cold-water service main where it enters the building ahead of main valve on water pipe main. Also, provide a driven ground per NEC 250-81 (a). Provide all necessary grounding clamps and full-size jumpers around all valves, meters, and similar fittings between point of connection and street main. The main grounding conductor shall be connected to the neutral conductor at one location only, within and on the low voltage side of the main transformer and more specifically the equipment grounding bus associated with the main insulated neutral bus in the MDP. The insulated neutral bus must be insulated and serve to provide the neutral source for all the insulated neutral conductors of the system. Jumpers shall be installed to connect the insulated neutral bus to the uninsulated grounding bus and all grounding and bonding of equipment (not neutrals) shall be attached to the uninsulated grounding bus.

System and equipment grounds shall be checked for proper value of resistance using the Megger ground tester in accordance with the method prescribed by the manufacturer of the instruments. Resistance of ground shall not be in excess of 25 ohms, measured to include the grounding cable. The Contractor shall report the results of these tests to the Engineer in writing. If the resistance cannot be reduced to the value prescribed above, further instructions will be given the Contractor.

All equipment connected under this section shall be grounded and shall conform with the more stringent requirements of the NEC, National Electrical Safety Code, the N. C. State Building Code, or this specification.

Panels, junction boxes, safety switches, disconnect switches, contactors, starters, motors, dry transformers, bus duct and other equipment shall be bonded to the conduit system with a grounding conductor by means of grounding locknuts and bushings as required hereinafter, except where conduit terminates in threaded hub or fittings. All joints or terminations shall be made with standard tapered pipe threads drawn tight to preserve electrical continuity.

Provide grounding bushings and copper jumpers across all concentric or eccentric knockouts and on all conduits larger than 1". Elsewhere, double-lock-nuts with plastic or fiber bushings, or a single lock-nut and malleable bushing may be used. If Contractor selects to use a single locknut and malleable bushing, care shall be taken that the full number of threads project through to permit the bushing to pull tight against the ends of the conduit, after which the lock-nut shall be made up sufficiently tight to draw the bushing into firm electrical contact with the box.

Where flexible conduits are used, provide grounding conductor within flexible conduit to ensure continuity of ground. Minimum size of jumper around flex shall be No. 10.

**EQUIPMENT IDENTIFICATION:**

Provide black-on-white laminated plastic name plates for each switch or circuit breaker on service equipment, disconnect switches, terminal cabinets, panelboards and wiring troughs. The name plate shall be engraved to indicate the equipment controlled or identified. Name plates shall be securely fastened to equipment using two screws.

**CONNECTIONS TO EQUIPMENT:**

Electrical Contractor shall provide rough-in, junction box, or wiring trough as indicated. Electrical Contractor shall provide and install disconnect switches and motor starters for equipment provided under Division 16. All external disconnect switches, motor starters, and any fuses required for equipment furnished under Division 15 shall be provided by the Div 15 contractor and installed by the Electrical Contractor. Coordinate all equipment locations with all other contractors prior to installation of electrical equipment. Consult all Contract drawings which may affect location of equipment or apparatus furnished by others and make any minor adjustments as required. Electrical Contractor is responsible for all line side and load side wiring for all equipment requiring electrical power. Line side wiring is defined as the wiring from the distribution panel

circuit to the point of disconnect (internal or external) for the equipment, whether provided by the contractor or factory installed by the equipment manufacturer. Load side wiring is defined as the wiring from the point of disconnect to all equipment requiring electrical power. All final electrical terminations to the piece of equipment shall be done by the contractor providing the equipment.

Electrical Contractor must closely coordinate with the equipment supplier regarding Voltage, H. P., F. L. A., outlet mounting heights, connection cord plug-receptacle electrode configurations and other special wiring requirements.

Electrical Contractor is responsible for coordinating quantity and location of all sprinkler system devices with sprinkler contractor.

Electrical Contractor shall review the Architectural, Civil, Plumbing, Mechanical, Fire Alarm and IC plans to provide branch circuits and final connections to powered equipment furnished by others for complete and operational equipment. This is a sample list and may not represent all connections required:

- 1) Data Equipment Racks not in MDF or IDF rooms.
- 2) HVAC Controls Equipment
- 3) Controlled Access electrified security doors (See Door Hardware Schedule)
- 4) Sprinkler controls/panels
- 5) Projectors and associated screens
- 6) Hand Dryers (See Architectural plans and elevations)
- 7) Electric Water Heaters & Associated Recirculation Pumps (Refer to Plumbing Plans)
- 8) Clothes Washers and Dryers
- 9) Fire Pumps (Main and Jockey)
- 10) Fire Alarm Control Panels and Booster Panels (See FA Contractor Shop Drawings)
- 11) Motorized Basketball Goals and/or Gym Divider Curtains
- 12) Scoreboards and Shot Clocks
- 13) Motorized Bleachers
- 14) PA Systems and associated amplifiers (Gym, Café, Auditoriums and MP Rooms)
- 15) Powered Hotboxes (See Civil Site Plan for exact locations)

*END OF SECTION*

**PART 1 - GENERAL**

1.1 Description of Work:

It is the intent of this specification to describe a standby power generator system that has been prototype tested, factory built, production tested, site tested, of the latest commercial design, together with all accessories necessary for a complete and operational installation per the design documents. The equipment supplied and installed shall meet the requirements of the National Electrical Code and all applicable local codes and regulations. All equipment shall be new, of current production by a national firm which manufactures the generator, controls, and assembles the generator set as a matched unit so that there is one source responsibility for warranty, parts, and service through a local representative with factory-trained service personnel. The firm shall have a minimum of 10 years experience in manufacturing systems of the type specified herein.

1.2 Submittal:

Submittal shall include specification sheets showing all standard and optional accessories to be supplied, schematic wiring diagrams, dimension drawings, and interconnection diagrams identifying by terminal number each required interconnection between the generator set and other remote devices if included elsewhere in these specifications. Generator sizing calculations as well as fuel tank sizing calculations shall be included in submittal.

1.3 Testing:

To assure that the equipment has been designed and built to the highest reliability and quality standards, the manufacturer shall be responsible for design prototype tests as described herein. Components of the emergency system, such as the engine/generator set, transfer switch, and accessories shall not be subjected to prototype tests since the tests are potentially damaging. Rather, similar design prototypes, which will not be sold, shall be used for these tests. Prototype test programs shall include the requirements of NFPA-110 and the following:

1. Maximum power (kw).
2. Maximum starting (kva) at 35% instantaneous voltage dip.
3. Alternator temperature rise by embedded thermocouple and by resistance method per NEMA MG1-22.40 and 16.40.
4. Governor speed regulation under steady-state and transient conditions.
5. Voltage regulation and generator transient response.
6. Fuel consumption at  $\frac{1}{4}$ ,  $\frac{1}{2}$ ,  $\frac{3}{4}$ , and full load.

7. Harmonic analysis, voltage waveform deviation, and telephone influence factor.
  8. Three-phase line-to-line short circuit test.
  9. Cooling airflow.
  10. Torsional analysis testing to verify that the generator set is free of harmful torsional stresses.
  11. Endurance testing.
- 1.4 Warranty:  
The emergency generator system shall be warranted by the manufacturer for one year or 2,000 hours, whichever occurs first, from the date of the site start-up.

## **PART 2 - PRODUCTS**

The standby generator set shall be rated standby power (defined as continuous operation for the duration of any power outage) voltage as indicated on plans (typically 480V or 208V), 3 phase, 4 wire, 0.8 power factor, and kw rating as indicated on plans. The generator shall be capable of handling the inrush current from starting and running the largest single motor load x 125%.

- 2.1 Final Production Tests:  
Each generator set shall be tested under varying loads with guards and exhaust system in place. The tests shall include the following:
1. Single-step load pickup.
  2. Transient and steady-state governing.
  3. Safety shutdown device testing.
  4. Voltage regulation.
  5. Rated power.
  6. Maximum power.

Upon request, arrangements to witness this test will be made or a certified test record will be sent prior to shipment.

- 2.2 Engine:  
The engine shall run at a governed speed not to exceed 1,800 rpm. The engine shall be equipped with the following:
1. Engine driven or electric fuel transfer pump, fuel filters and electric fuel shut-off valve.
  2. Gear driven governor capable of regulating the no load to full load frequency to a 5% maximum and capable of 0.33% Steady State frequency regulation.

3. 12 volt positive engagement solenoid shift-starting motor.
4. Battery charging alternator with solid-state voltage regulation.
5. Positive displacement, full pressure lubrication oil pump, cartridge oil filters, dipstick, and oil drain.
6. Dry-type replacement air cleaner elements.
7. NOTE: Engines requiring glow plugs will not be acceptable when NFPA-99 or NFPA-110 Type 10 (ten-second) transfer requirement must be met.

The naturally aspirated or turbo charged engine shall be fueled with No. 2 diesel, and shall be liquid cooled. A unit-mounted radiator, blower fan, water pump, thermostat, and radiator duct flange (unhoused only) shall properly cool the engine with up to 0.5 inches H<sub>2</sub>O external static pressure on the cooling system.

### 2.3 Generator:

The alternator shall be salient-pole, reconnectable, 12-lead, self ventilated, of drip-proof construction with amortisseur rotor windings and skewed for smooth voltage waveform. The insulation material shall meet the NEMA standard (MGI-22.40 and 16.40) for Class H and be vacuum impregnated with epoxy varnish to be fungus resistant per MIL I-24092 or be multiply dipped and baked with nonhygroscopic varnish with a final dip of epoxy. The excitation system shall be brushless construction controlled by a solid-state voltage regulator with adjustable volts-per-Hertz operation capable of maintaining voltage within  $\pm 2\%$  at any constant load from 0 to 100% of rating. The regulator must be sealed from the environment and isolated from the load to prevent tracking when connected to SCR loads.

On application of any load up to the rated load, the instantaneous voltage dip shall not exceed 20% and shall recover to  $\pm 2\%$  of rated voltage within one second.

The generator shall be capable of sustaining at least 250% of rated current for at least 10 seconds under a 3 phase symmetrical short by inherent design or by the addition of an optional current boost system.

The generator shall be capable of accepting the loads that were specified with the A/C equipment being the largest running loads and 15% being the largest instantaneous voltage dip when loads are started as specified on the loads report.

A resettable line current sensing circuit breaker with inverse time versus current response shall be furnished and shall not automatically reset preventing restoration of voltage if maintenance is being performed. This breaker shall protect the generator from damage due to its own high current capability and shall not trip within the 10 seconds specified above to allow selective tripping of downstream fuses or circuit breaker under a fault condition.

The generator, having a single maintenance free bearing, shall be directly connected to

the flywheel housing with a semiflexible coupling between the rotor and the flywheel.

2.4 Controller:

Set-mounted controller capable of facing right, left, or rear shall be vibration isolated on the generator enclosure. The microprocessor control board shall be moisture proof and capable of operation from -40C to 85C. Relays will only be acceptable in high current circuits.

Circuitry shall be of plug-in design for quick replacement. Controller shall be equipped to accept a plug-in device capable of allowing maintenance personnel to test controller performance without operating the engine. The controller shall include the following:

1. Fused DC circuits.
2. Complete two-wire start/stop control, which shall operate on closure of a remote contact.
3. Speed sensing and a second independent starter motor disengagement system shall protect against the starter engaging with a moving flywheel. Battery charging alternator voltage will not be acceptable for this purpose.
4. The starting system shall be designed for restarting in the event of a false engine start, by permitting the engine to completely stop and then reengage the starter.
5. Cranking cycler with 15-second ON and OFF cranking periods.
6. Overcrank protection designed to open the cranking circuit after 75 seconds if the engine fails to start.
7. Circuitry to shut down the engine when signal for high coolant temperature, low oil pressure, or over-speed is received.
8. Engine cool down timer factory set at five minutes to permit unloaded running of the standby set after transfer of the load to normal.
9. Three-position (AUTOMATIC-OFF-TEST) selector switch. In the test position, the engine shall start and run regardless of the position of the remote starting contacts. In the automatic position, the engine shall start when contacts in the remote control circuit close and stop five minutes after those contacts open. In the off position, the engine shall not start even through the remote start contacts close. This position shall also provide for immediate shutdown in case of an emergency. Reset of any fault lamp shall also be accomplished by putting the switch to the off position.
10. Indicating lights to signal:
  - 1) Not-in-auto (flashing red)
  - 2) Over-crank (red)
  - 3) Emergency Stop (red)
  - 4) High engine temperature/low coolant level (red)
  - 5) Over-speed (red)
  - 6) Low Oil Pressure (red)

- 7) \* Battery charger malfunction (red)
- 8) \* Low battery voltage (red)
- 9) \* Low fuel (red)
- 10) \* System ready (green)
- 11) \* Pre-alarm high engine temperature (yellow) - liquid cooled models
- 12) \* Pre-alarm low oil pressure (yellow)
- 13) \* Low coolant temperature (red) - liquid cooled models

\* Required to meet NFPA-99 or NFPA-110 Level 1 regulations.

11. Test button for indicating lights.
12. Alarm horn with silencer switch per NFPA-110.
13. Terminals shall be provided for each signal in 10 above for connection to remote monitoring devices.

2.5 Instrument Panel:

A set instrument panel shall include the following:

1. Dual range voltmeter, 3 ½", ±2% accuracy.
2. Dual range ammeter, 3 ½", ±2% accuracy.
3. Voltmeter-ammeter phase selector switch.
4. Lights to indicate high or low scale.
5. Direct reading pointer-type frequency meter, 3 ½", ±5% accuracy, 45 to 65 Hertz scale.
6. Panel illuminating lights.
7. Battery charging meter.
8. Coolant temperature gauge (liquid cooled models).
9. Oil pressure gauge.
10. Running time meter.
11. Voltage adjust rheostat (±5% range).

2.6 Accessories:

The following accessories shall be provided:

1. Over voltage protection will shut down the unit after one second of 15% more over voltage.
2. Battery rack, battery cables, 12-volt battery(ies) capable of delivering the minimum cold-cranking amps required at 0°Fahrenheit per SAE Standard J-537.
3. Gasproof, seamless, stainless steel, flexible exhaust connector(s) ending in pipe thread or SAE flange.
4. Flexible fuel lines rated 300°F and 100 PSI ending in pipe threads.
5. Engine exhaust silencer, coated to be temperature and rust resistant, rated for critical applications. Exhaust noise shall be limited to 85 dba as measured at 10 feet in a free-field environment.
6. Block heater of proper wattage and voltage, thermostatically controlled to

maintain engine coolant at 90°F (32°C) to meet the start up requirements of NFPA-99 or NFPA-110 regulations.

7. Trickle type battery charger with an adjustable low charge rate of 50 to 300 milli-amperes and a manual, high charge rate of 2 amperes.
8. Steel weather-protective enclosure with removable or hinged side panels to allow inspection and maintenance. The enclosure shall be coated with ASA gray primer and two coats of high-gloss, weatherproof, sag resistant vinylac in the manufacturer's standard color through an electrical bonding process. The specific exhaust silencer shall be vibration-mounted on the roof of the enclosure.
9. Vibration isolators shall be provided between the engine-generator and welded steel base.
10. A Min. 350 gallon sub-base mounted double wall steel fuel tank with level gauge and low-level alarm contract. Note: fuel tank volume shall be sized by genset provider to be sufficient for operation under full load for 48 hours.
11. Four (4) sets of keys shall be provided to the County.

2.7 Base Bid: Manual Transfer Switch – Alt Bid: Automatic Transfer Switch:

1. Except as otherwise indicated, provide manufacturer's standard design, materials and components as indicated by published project information, designed and constructed as recommended by manufacturer for duty indicated, and as required for a complete installation.
2. Transfer switch shall be capable of switching all classes of load and for continuous duty at the rated current with switch mounted in the enclosure.
3. The transfer switch shall be double throw type disconnect. (Alt Bid) Automatic Transfer switch shall be actuated by two electrical operators momentarily energized and connected to the transfer mechanism by a simple over-center linkage with a transfer time of 3 seconds. The time delay of 3 seconds between the opening of the closed contacts and the closing of the open contacts is to allow the loads to be demagnetized before transfer. The transfer switch shall be capable of transferring successfully in either direction with 70% of rated voltage applied to the switch terminals.
4. The normal and standby contacts shall be positively interlocked mechanically and electrically to prevent simultaneous closing. Main contacts shall be mechanically locked in position in both the normal and standby positions without the use of hooks, latches, magnets, or springs and shall be silver tungsten alloy protected by arcing contacts with magnetic blowouts in each pole. Interlocked molded case circuit breakers will not be acceptable.
  5. The transfer switch shall be equipped with a safe manual operator that has been designed to prevent injury to the operating personnel if the electrical operator should suddenly become energized during manual transfer. The manual operator shall provide the same contact opening



- and closing speed as the electrical operator to prevent a flashover from switching the main contacts slowly.
6. Engine starting contacts shall be provided to start the generating plant if any phase of the normal source drops below 80% of rated voltage after a nonadjustable time delay period of 3 seconds to allow for momentary dips. The transfer switch shall transfer to standby as soon as the voltage and frequency have reached 90% of rating. After restoration of normal power on all phases to 90% of rated voltage, an adjustable time delay period of 0-30 minutes shall delay retransfer to normal power until it has had time to stabilize. If the standby power source should fail during the time delay period, the time delay shall be bypassed and the switch shall return immediately to the normal source. After the switch has retransferred to normal, the engine generator shall be allowed to operate at no load for an adjustable period of 5-30 minutes to allow it to cool before shutdown. The transfer switch shall include a test switch to simulate normal power failure, a test input to simulate a normal power failure upon closure of a SCADA dry contact provided for remote start, pilot lights on the cabinet door to indicate the switch closed on normal or emergency, and four spare auxiliary contacts on the main shaft, two closed on normal and two closed on emergency. All relays, timers controls, wiring, and accessories to be front accessible.
  7. The transfer switch, complete with all timers, relays, and accessories shall be listed by Underwriters' Laboratories, Inc. at the time of the bid opening in their Electrical Construction Materials Catalogue under Standard UL-1008 (Automatic Transfer Switches) and approved for use on emergency systems. The UL listing shall include the specific amperage ratings that are called for in this specification.
  8. Transfer switch shall have adjustable over voltage, under voltage, phase reversal, and phase loss relays for the normal power source. Relays shall initiate transfer to standby if any abnormal voltage condition on the normal source occurs, including motor-generated voltages that occur during single phasing of the normal source.
  9. The transfer switch shall have a short circuit withstand capability of 50,000 RMS amperes symmetrical minimum. To establish conformance with the above, the manufacturer must produce certified test reports from an independent testing laboratory to verify that identical samples have been subjected to three phase short circuit at 480 VAC for a minimum of 3 cycles duration, without contact damage or contact welding, and without the use of current limiting fuse protection. Oscillograph traces are to be supplied to verify that the test parameters have been met.
  10. Transfer switch shall have one full-length door in front and shall be provided in a NEMA 3R enclosure for rack mounting.

### PART 3 - EXECUTION

- 3.1 The equipment shall be installed as shown on the plans with a reinforced concrete foundation sized in accordance with the manufacturer's recommendations and all applicable codes. All exposed edges of concrete foundation shall have a  $\frac{3}{4}$ "

chamfer. The concrete pad shall be a minimum of 12" in thickness with #5 rebar at 12" O.C. each way. The generator set concrete pad shall have a minimum of 6" exposed foundation on all sides of the pad.

3.2 Site Tests:

The manufacturer's local representative shall perform an installation check, start-up and a 4 hour minimum load test. The engineer and the County utility operating staff shall be notified of the time and date of the site test.

Contractor shall provide a full tank of fuel prior to testing.

Fuel, lubricating oil, and antifreeze (liquid cooled models) shall be checked for conformity to the manufacturer's recommendations under the environmental conditions present and expected.

Accessories that normally function while the set is standing by shall be checked prior to cranking the engine. This shall include engine heaters, battery charger, generator strip heaters and remote annunciator, etc.

Start-up under test mode to check for exhaust leaks, path of exhaust gases, cooling air flow, movement during starting and stopping, vibration during running, normal and emergency line-to-line voltage, and phase rotation.

Automatic start-up by means of simulated power outage to test remote-automatic starting, transfer of load and automatic shutdown shall be performed. Engine temperature, oil pressure, and battery charge level along with generator voltage, amperes, and frequency shall be monitored throughout the test.

Following testing and acceptance, the fuel tank shall be left at a full level, and a start-up report and spare parts must be furnished to the County.

**END OF SECTION**

**RELATED DOCUMENTS:**

Drawings and general provisions of Contract, including General and Supplementary Conditions and Division-1 Specification sections, apply to work of this section.

**TESTS:**

Test all lines to be concealed before burying or covering with new construction. Tests shall include proper operation of lights, receptacles, and equipment, continuity of conduit system, insulation leakage and impedance, elimination of motor single phasing or reverse rotation, and ground system resistance (see also Section 16400).

After the interior wiring system is completed and at such time as the Engineer or Owner's representative may direct, the Contractor shall conduct an operating test for approval. The tests shall be performed in the presence of the authorized representative of the Engineer and the installation shall be demonstrated to operate in accordance with the requirements of this specification. The Contractor shall furnish all instruments and personnel required for the test. The Contractor shall have sufficient tools and personnel available at the scheduled inspection to remove panel fronts, device plates, etc., as required for proper inspection of equipment, devices and wiring installation as may be required by the inspectors. Any material or workmanship which does not meet with approval of the engineer shall be promptly removed, repaired or replaced as directed, at no additional cost to the Owner.

**ADJUSTMENTS:**

Adjustments shall include load balancing of all electrical phases, at devices and panels. Balance all panelboards so that the maximum deviation of any one phase from the average of all the phases shall not exceed 10%. Re-type circuit directory as required after completion of adjustment.

**CLEANING AND PAINTING:**

Prior to final inspection, all equipment having factory finishes shall be thoroughly cleaned inside and outside. All damaged surfaces shall be replaced or refinished by Contractor, with paint same as original manufacturer. Engineer shall determine whether the damaged surface is to be replaced or painted.

**RECORD DRAWINGS:**

The Contractor shall maintain accurate records of all deviations in work as actually installed from work indicated on the drawings. On completion of the project, two (2) complete sets of marked-up prints shall be delivered to the Architect.

**OPERATING AND MAINTENANCE INSTRUCTIONS:**

Unless directed otherwise elsewhere in these specifications, the Contractor shall compile and bind three sets of all manufacturer's instructions and descriptive literature on all items of equipment furnished under this work. These instructions shall be delivered to the Engineer for approval prior to final inspection. Instructions shall include operating and testing procedures and a parts list of all equipment. The Contractor shall instruct the Owner's personnel in the proper operation of all systems and equipment. The front and side of the binder shall be titled "Electrical Operating and Maintenance Instructions", with name of the job and firm name of the Contractor.

**WARRANTY:**

The Contractor shall submit upon completion of the work, a warranty by his acceptance of the contract, that all work installed will be free from defects in workmanship and materials. If, during the period of one year, or as otherwise specified from date of Certificate of Completion and acceptance of work, any such defects in

workmanship, materials, or performance appear, the Contractor shall, without cost to the Owner, remedy such defects within reasonable time to be specified in notice from the Architect. In default, the Owner may have such work done and charge cost to Contractor.

*END OF SECTION*

*END OF SPECIFICATIONS*